

**DC MOTORIZED
LINEAR ACTUATOR**

**DC MOTORISIERT
LINEARANTRIEB**

WEKS products WKKB Control Box
and WEKB hand control
can be used without 24VDC.

WELS Produkte WKKB Control Box
und WEBB-Handsteuerung
kann ohne 24VDC verwendet werden.

**WKKB CONTROL BOX
WKKB STEUERBOX**

**WEKB HAND CONTROL
WEKB HANDSTEUERUNG**

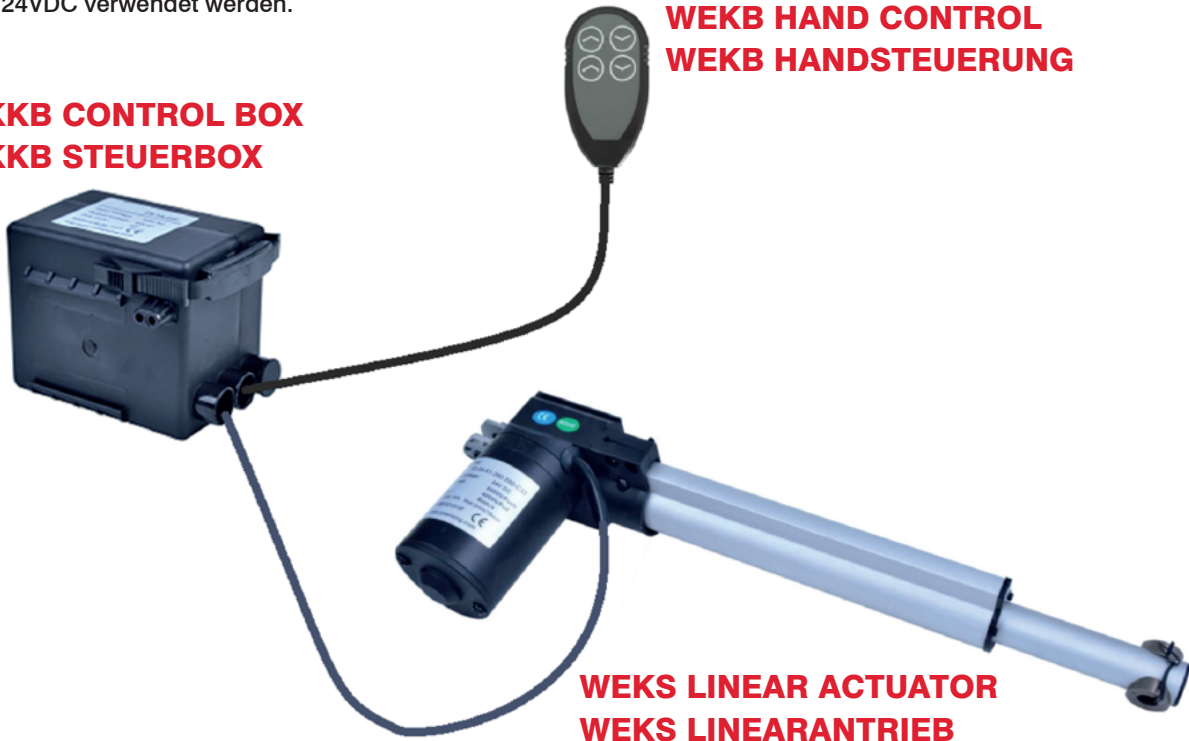

**WEKS LINEAR ACTUATOR
WEKS LINEARANTRIEB**

WEKS LINEAR ACTUATOR/ WEKS LINEARANTRIEB



Technische Spezifikationen/Technical Specifications

Limit sensors are available at the start and end positions of the products
 Products noise level ≤ 48 dB
 The duty cycle value of the products is 10% (after 18 minutes of 2 minutes of continuous operation)
 Speed is indicated for idle operation
 Operating temperatures of products $-20 + 40$ C

Grenzwertsensoren sind an den Start- und Endpositionen der Produkte verfügbar
 Geräuschpegel der Produkte ≤ 48 dB
 Der Arbeitszyklus der Produkte beträgt 10% (nach 18 Minuten Dauerbetrieb von 2 Minuten).
 Die Drehzahl wird für den Leerlauf angezeigt
 Betriebstemperaturen von Produkten $-20 + 40$ ° C

Technische Zeichnung / Technical Drawing

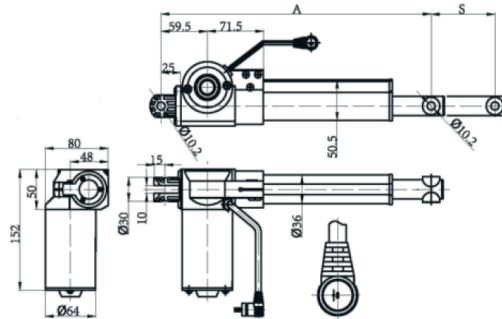

CODE	PUSH FORCE DRÜCKEN KRAFT [N]	PULL FORCE ZIEHEN KRAFT [N]	SPEED GESCHWINDIGKEIT [mm/s]	VOLTAGE	IP CLASS	S [mm] STROK	A [mm]
WEEKS-24-04-30	6000	4000	4	24V DC	44	30	190
WEEKS-24-04-50	6000	4000	4	24V DC	44	50	210
WEEKS-24-04-100	6000	4000	4	24V DC	44	100	260
WEEKS-24-04-150	2000	1000	12	24V DC	44	150	310
WEEKS-24-04-200	6000	4000	4	24V DC	44	200	360
WEEKS-24-04-300	6000	4000	4	24V DC	44	300	480
WEEKS-24-04-500	6000	4000	4	24V DC	44	500	750

Speed VS Load

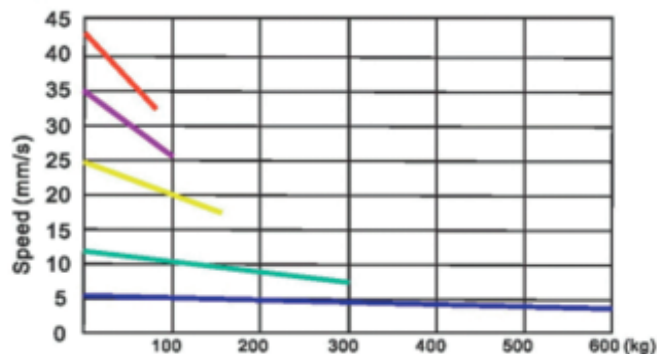

WKKB CONTROL BOX / WKKB STEUERKASTEN



Technische Spezifikationen/Technical Specifications

Duty cycle value of products is 10% (18 minutes rest after 2 minutes of operation)
 Operating temperatures of products -20 + 40 C
 IP Class of Products 51

Einschaltdauer der Produkte beträgt 10% (18 Minuten Pause nach 2 Minuten Betrieb)
 Betriebstemperaturen von Produkten -20 + 40 ° C
 IP-Produktklasse 51

Technische Zeichnung / Technical Drawing

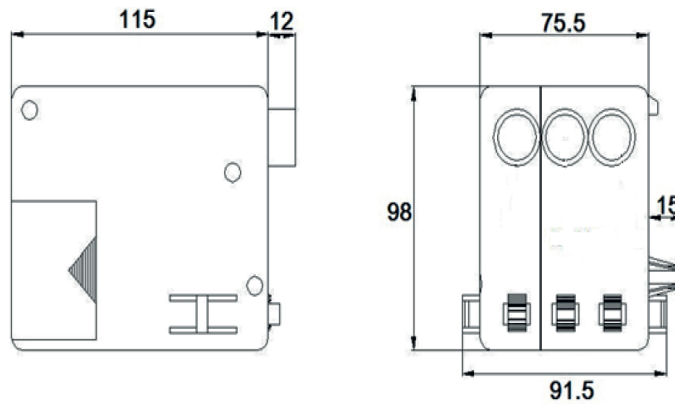

WKKB2A

WKKB2A

CODE	NUMBER OF WEEKS TO BE CONNECTED [piece] ANZAHL DER WEEKS ZU VERBINDEN [Stück]	NUMBER OF WEKB TO BE CONNECTED [piece] ANZAHL DER WEKB ZU VERBINDEN [Stück]	LOGIN VOLTAGE EINFÜHRUNG VOLTAGE	EXIT VOLTAGE	MAX FLOW STROM [A]
WKKB1A	1	1	230VAC 50HZ	24V DC	5
WKKB2A	2	1	230VAC 50HZ	24V DC	5

WEKB HAND CONTROL / WEKB-HANDSTEUERUNG**WEKB2****WEKB4****Technische Spezifikationen/Technical Specifications**

Duty cycle value of products is 10% (18 minutes rest after 2 minutes of operation)

- Operating temperatures of products -20 + 40 C
- IP Class of Products 51

Einschaltdauer der Produkte beträgt 10% (18 Minuten Pause nach 2 Minuten Betrieb)

- Betriebstemperaturen der Produkte -20 + 40 C
- IP-Produktklasse 51

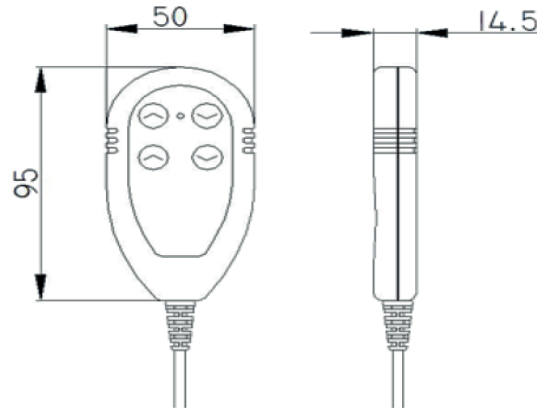
Technische Zeichnung / Technical Drawing

CODE	ANZAHL DER ÜBERPRÜFBARE WEKS Stück) NUMBER OF CHECKABLE WEKS (PIECE)
WEKB2	1
WEKB4	2